

INSTRUCTION MANUAL

1/10 Scale 4WD RC Nitro & Electric Powered Car



RH1027 XR4 EBD (Brushed)

RH1028 XR4 EBL (Brushless)

RH1029 XR4 N1 (single speed)

RH1030 XR4 N2 (Two Speed)

INSTRUCTION MANUAL

RH1029 XR4 N1 (single Speed)

Specs :

- 1、Length: 465mm
- 2、Width: 256mm
- 3、Height: 180mm
- 4、Wheelbase: 275/280mm
- 5、Gear Ratio: 9.1: 1
- 6、Tyre: Ø95*40

Standard Equipments:

- 1、Steering Servo: 3kg/cm
- 2、Throttle Servo: 3kg/cm
- 3、Engine: G0.18 or SH.18
- 4、Radio: 2CH AM

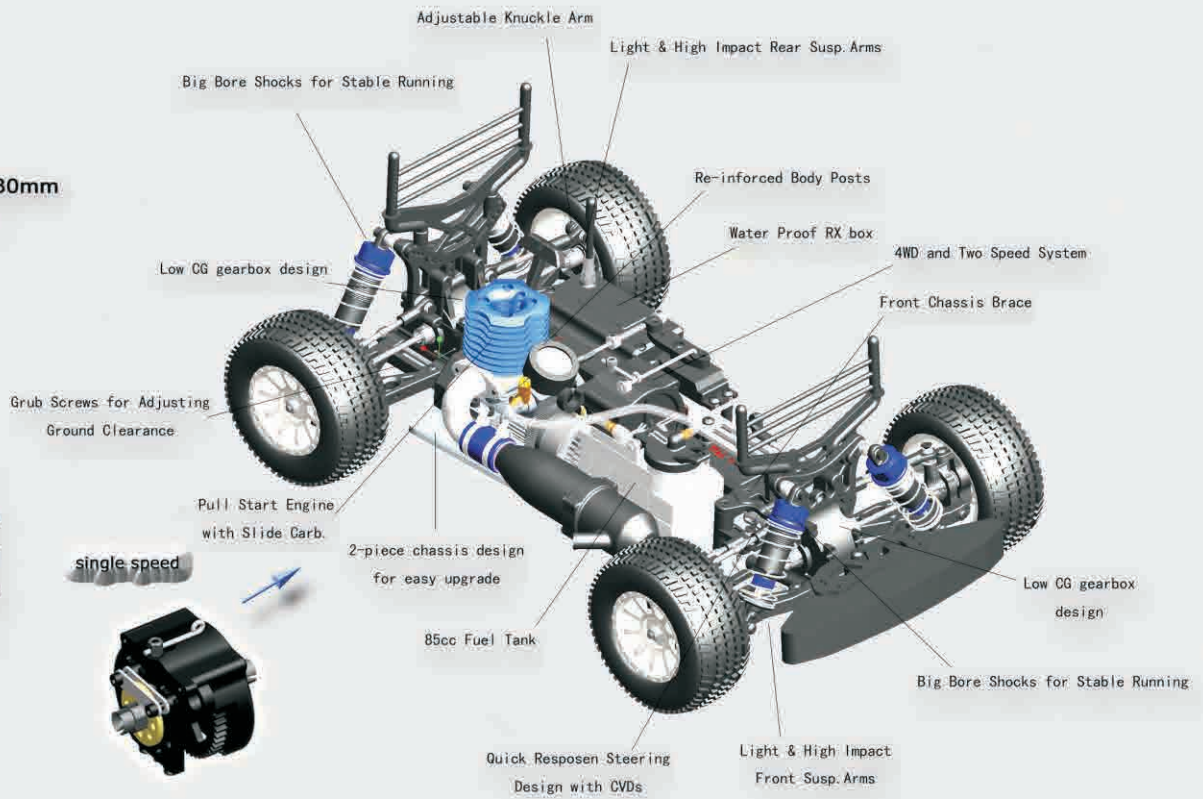

RH1030 XR4 N2 (Two speed)

Specs :

- 1、Length: 465mm
- 2、Width: 256mm
- 3、Height: 180mm
- 4、Wheelbase: 275/280mm
- 5、Gear Ratio: 6.1:1 (H) 9.1:1 (L)
- 6、Tyre: Ø95*40

Standard Equipments:

- 1、Steering Servo: 3kg/cm
- 2、Throttle Servo: 3kg/cm
- 3、Engine: G0.18 or SH.18
- 4、Radio: 2CH AM

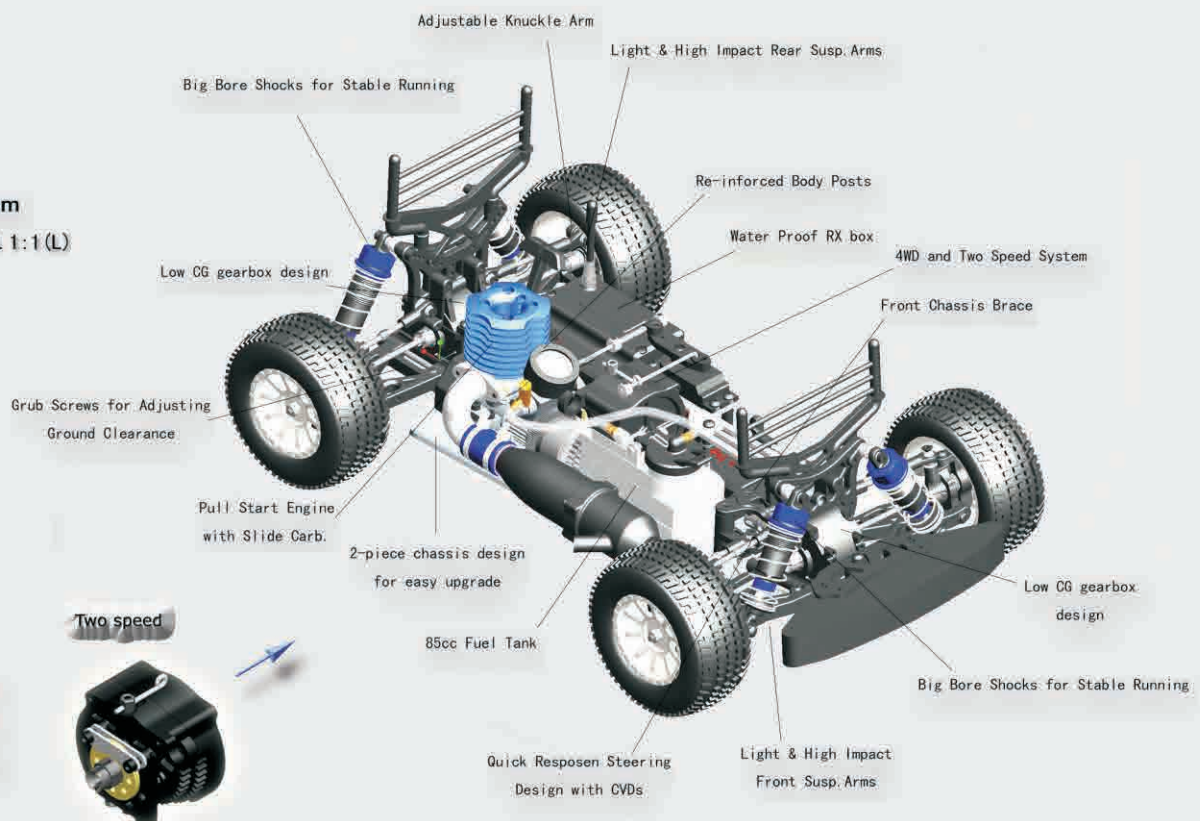

FRONT & REAR SHOCK ASSEMBLY

Front Shocks

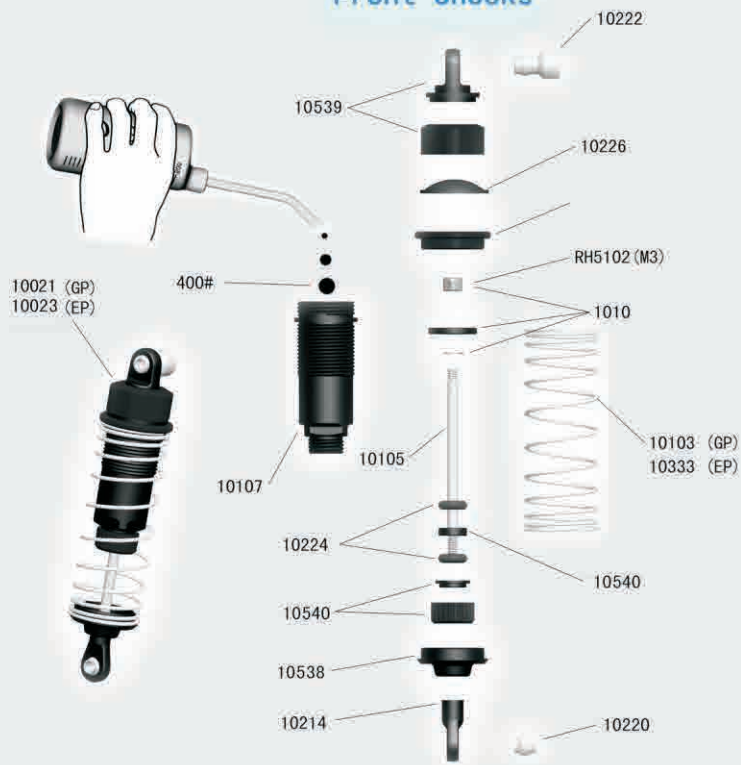

(Dia. 2-1)

Rear Shocks

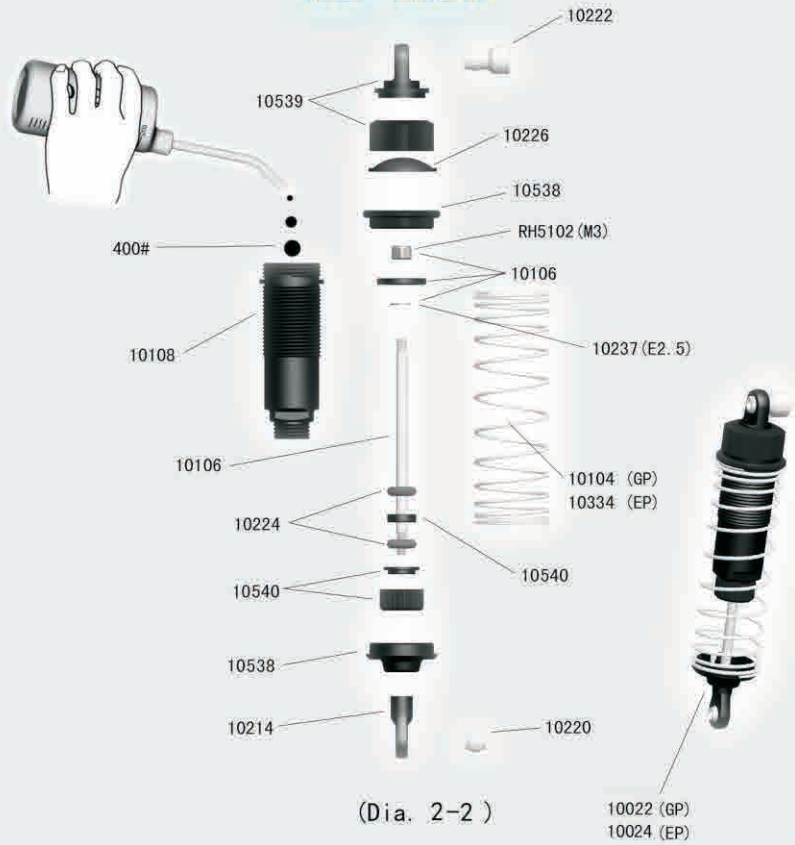

(Dia. 2-2)

Chassis Assembly

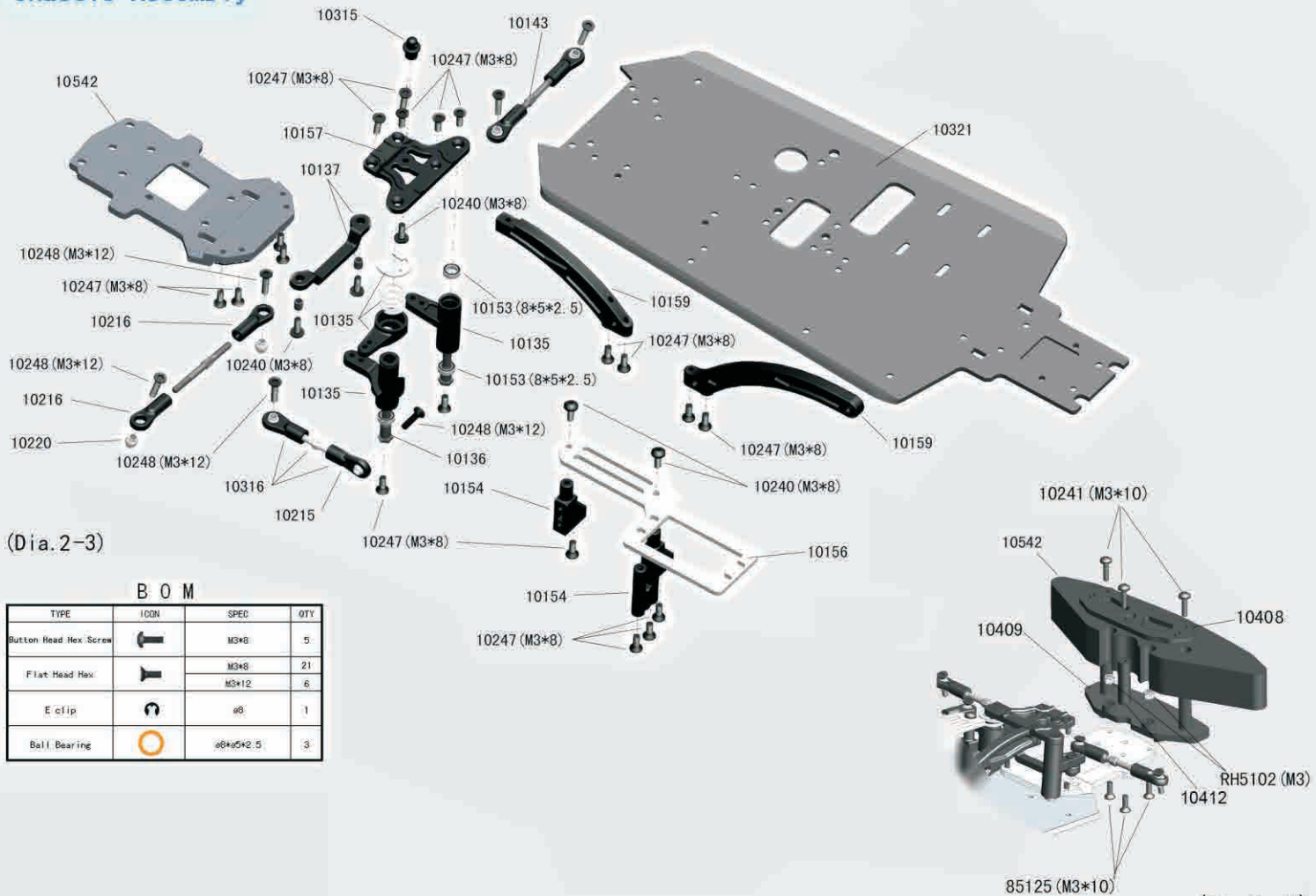

(Dia. 2-3)

B O M

TYPE	ICGN	SPEC	QTY
Button Head Hex. Screw		M3*8	5
Flat Head Hex.		M3*8	21
		M3*12	6
E clip		ø8	1
Ball Bearing		ø8*ø5*2.5	3

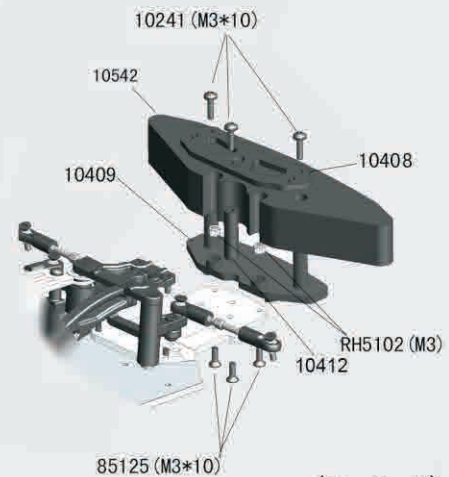

(Dia. 2-4)

B O M

TYPE	ICON	SPEC	QTY
Round Head Self Tapping Hex Screw		2*6	4
Button Head Hex Screw		M3*8	4
Cap Head Hex Screw		M3*15	2
		M3*28	5
Flat Head Hex		M3*10	1
Set Screw		M4*4	1
Washer		ø6*3.1*0.2	1
Nylon Lock Nut		M3	5
O' Ring		ø31* 02	1
Ball Bearing		ø10*ø5*4	2

Engine Assembly

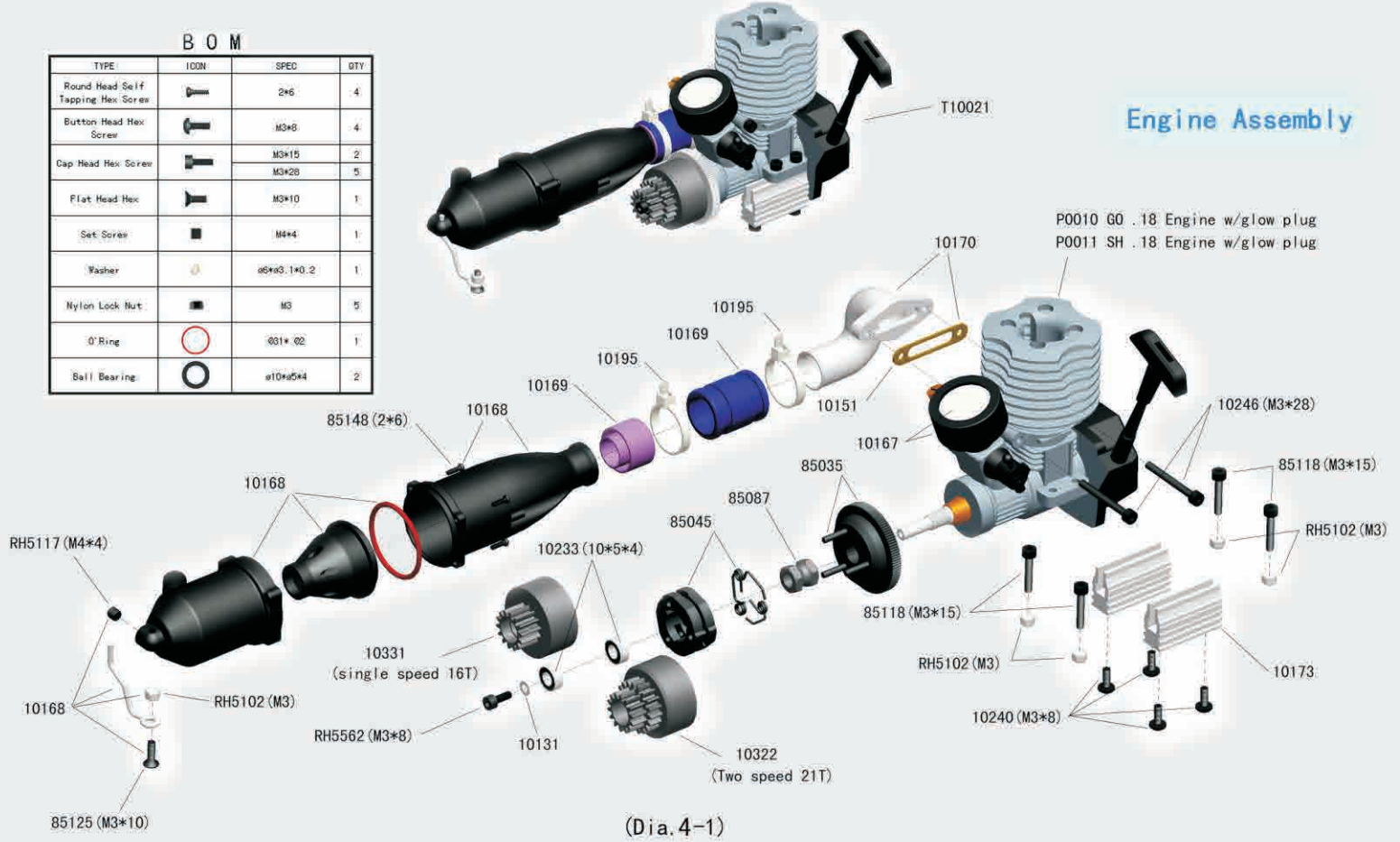

SPiRiT N1 Central Trammision

B O M

TYPE	ICON	SPEC	QTY
Cap Head Hex Screw		M3*10	2
Flat Head Hex		M3*8	4
		M3*20	2
Set Screw		M3*3	1
		M4*4	2
E clip		ø4	3
Ball Bearing		ø10*ø5*4	2

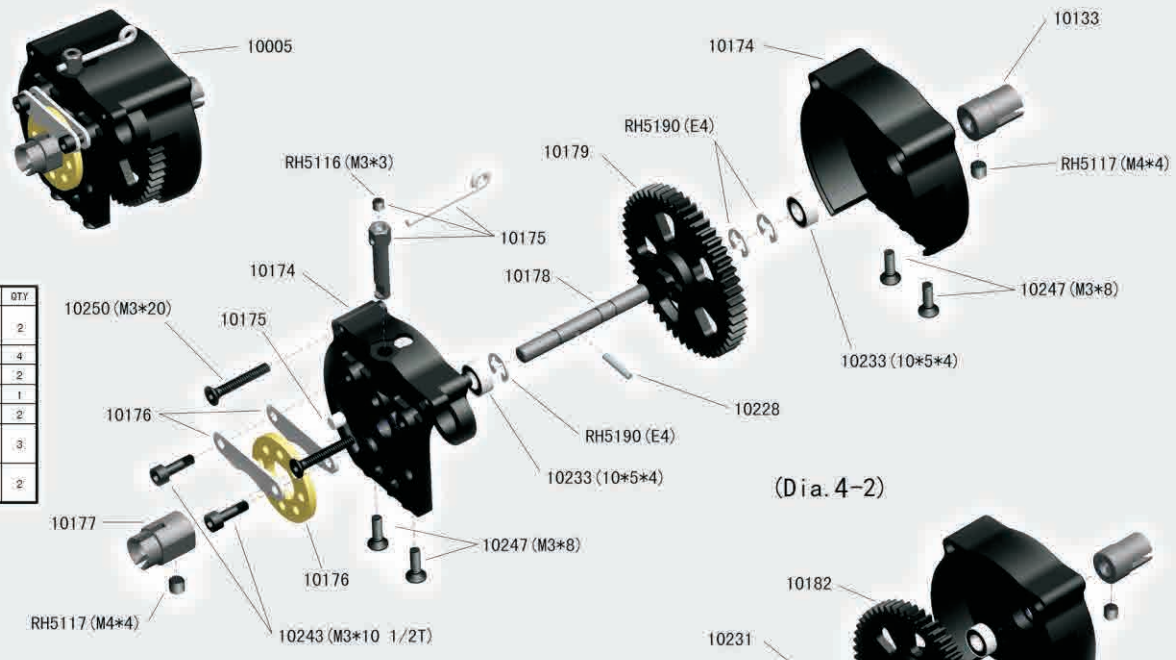

SPiRiT N2 Central Trammision

B O M

TYPE	ICON	SPEC	QTY
Cap Head Hex Screw		M3*10	2
Flat Head Hex		M3*8	4
		M3*20	2
Set Screw		M3*3	1
		M4*4	4
E clip		ø4	1
One Way Bearing		ø12*ø6.3*8.4	1
Ball Bearing		ø10*ø5*4	3

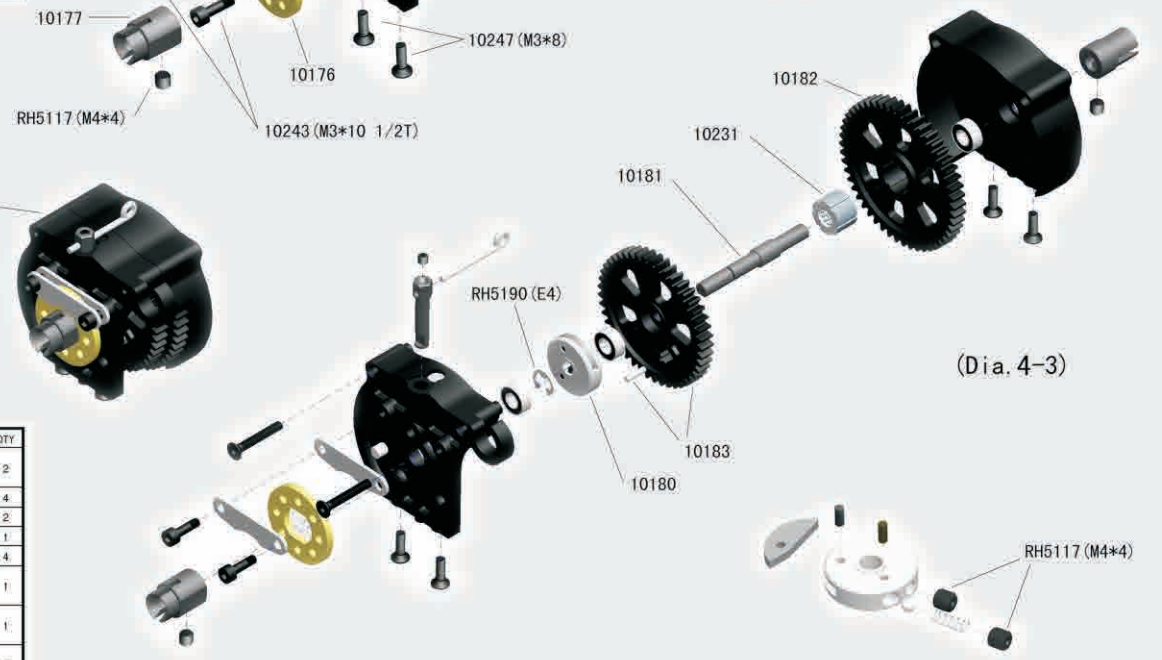

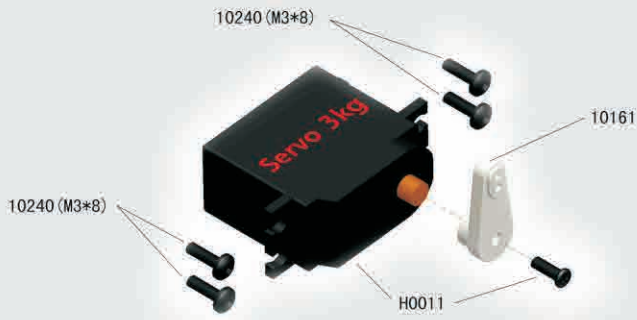

Steering Servo



(Dia. 5-1)

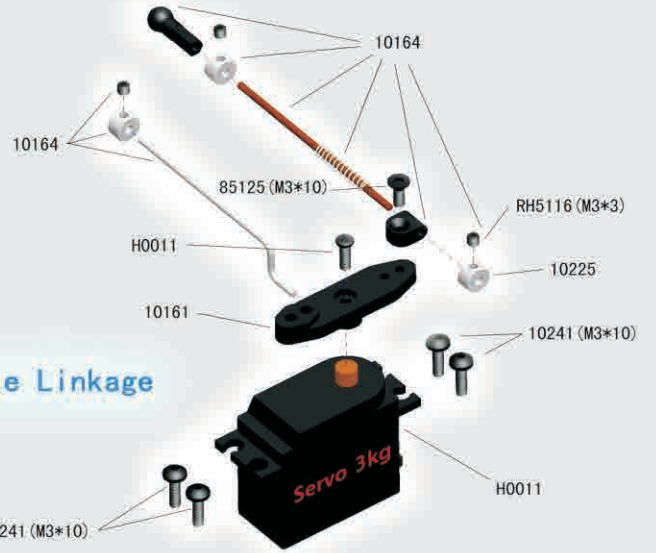

Throttle Linkage



10241 (M3*10)

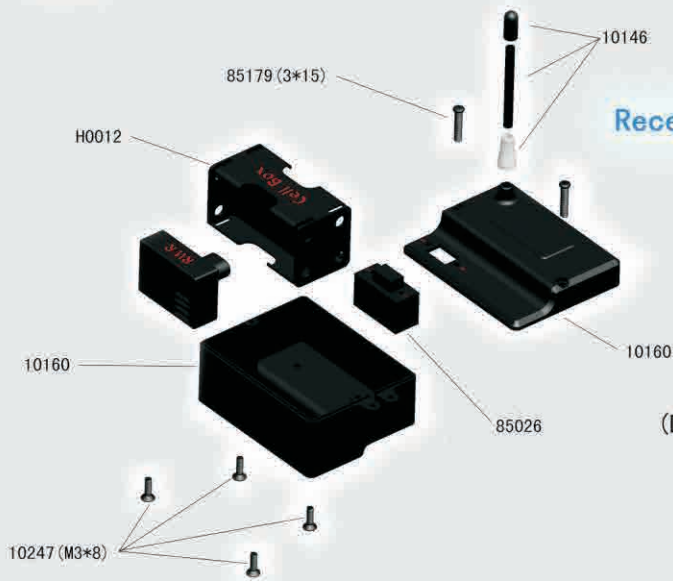

Receiver Assembly



(Dia. 5-3)



(Dia. 5-2)

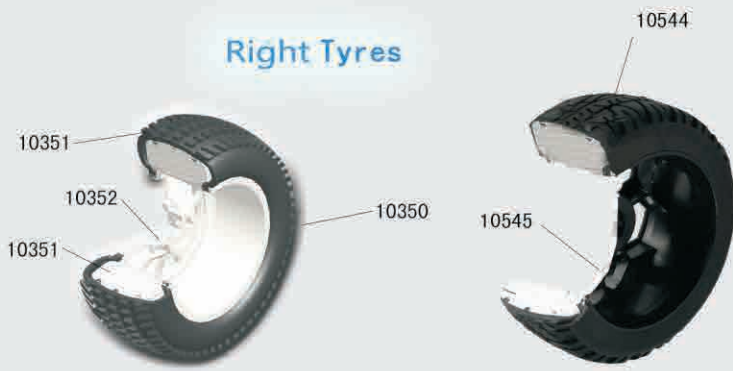

Right Tyres

(Dia. 5-4)



Left Tyres

(Dia. 5-5)

Fuel Tank

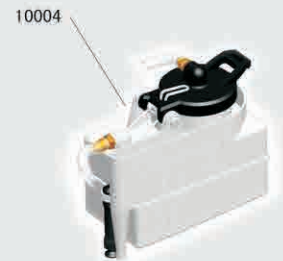

(Dia. 5-6)

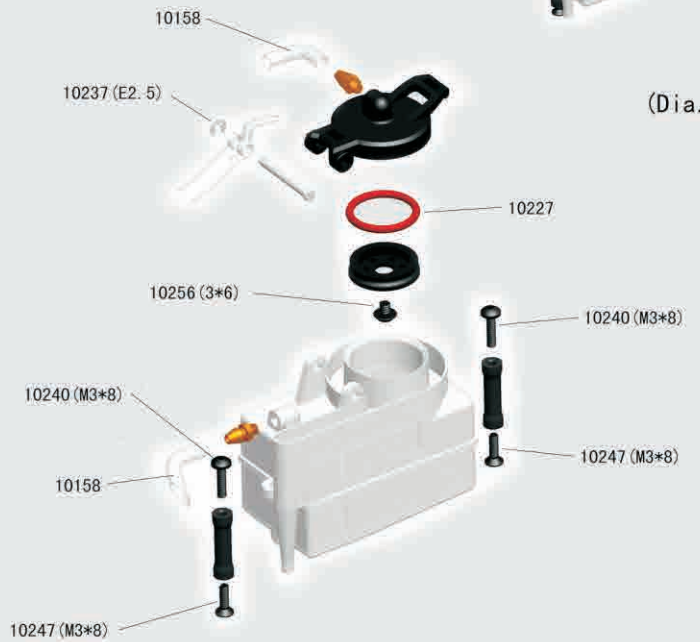

XR4 N1 and N2 are almost in structure but the central transmission (Diagram 4-2 and 4-3).
 For hobbyists, we have optional front and rear sway bar for upgrade, which adds higher racing performance.
 Optional Front & Rear Sway Bar #10324.

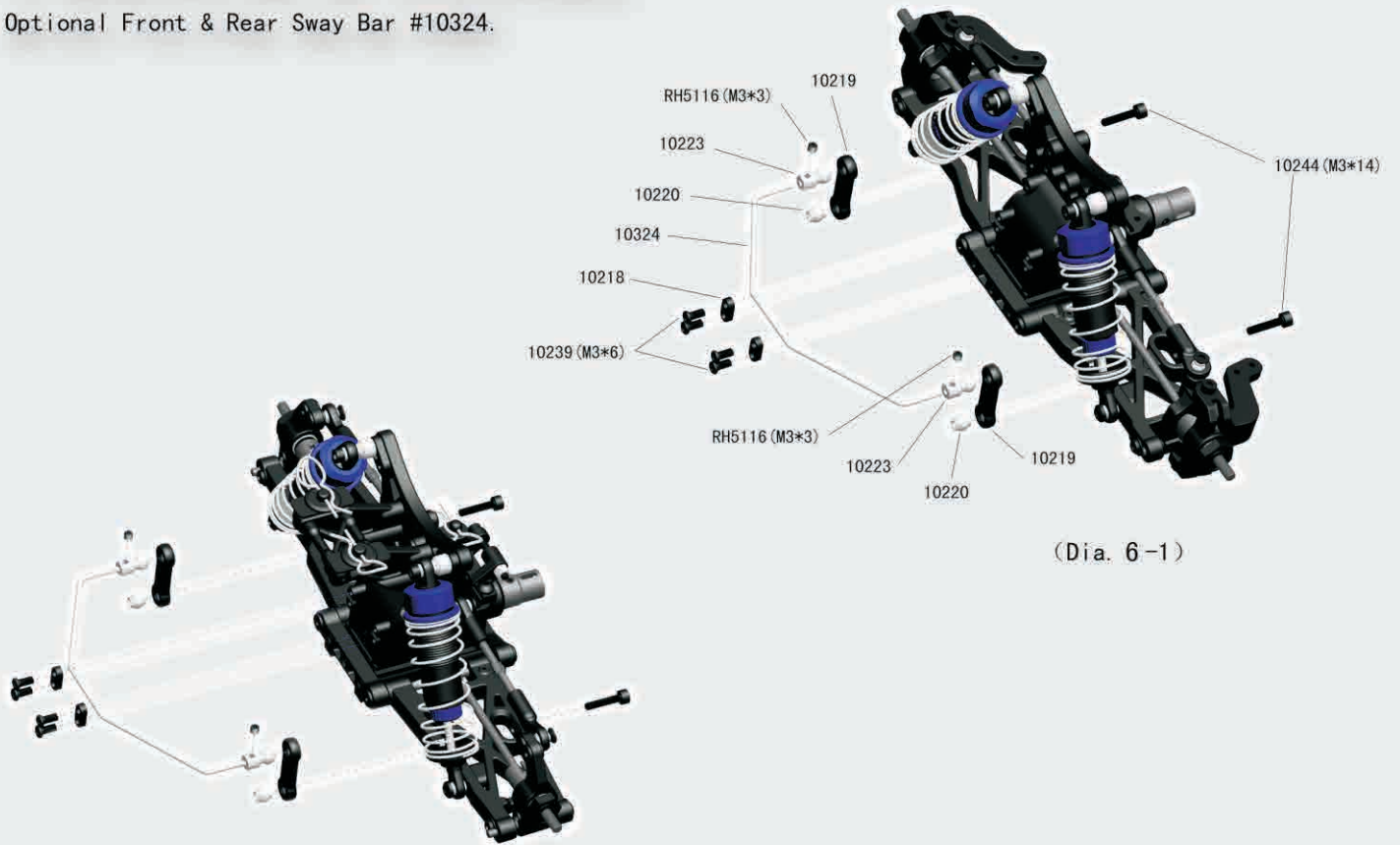

(Dia. 6-1)

(Dia. 6-2)

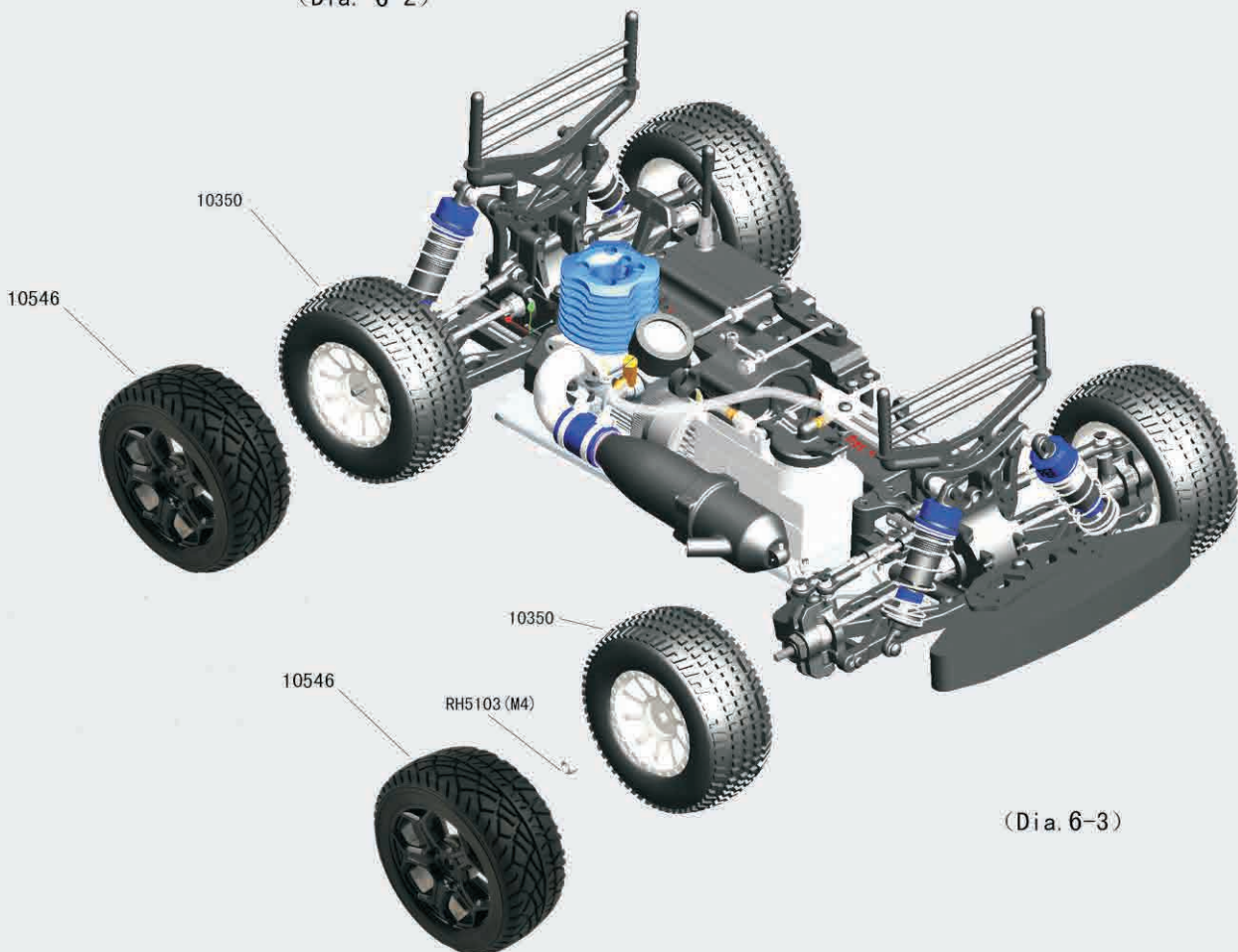

(Dia. 6-3)

Assembly Steps:

1. Fasten the fuel tank posts to the chassis, then the fuel tank assembly. (See Dia. 5-6)

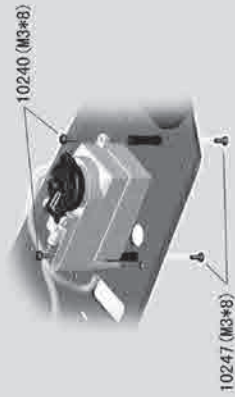

2. Assemble Chassis. (See Dia. 2-3)

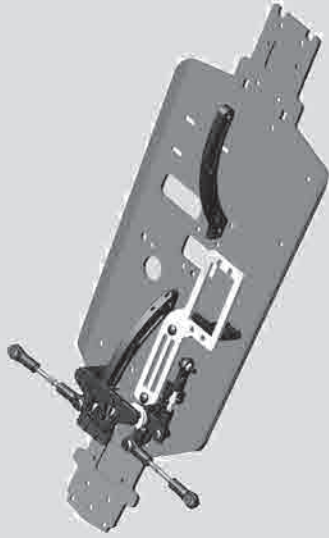

3. Assemble Front Bumper Assembly to chassis rear part. (See Dia. 2-4)

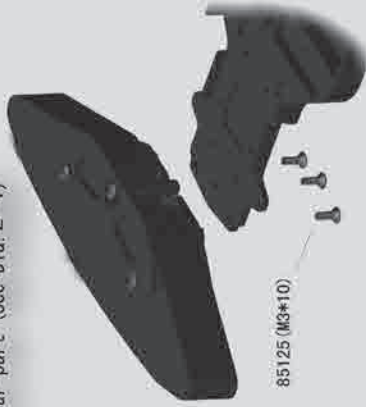

4. Assemble the front assembly to the chassis. (See Dia. 3-1)



5. Assemble the rear assembly to the chassis. (See Dia. 3-4)



6. Tighten the wheels. (See Dia. 5-4 or 5-5)



7. Assemble central transmission and rear central drive shaft to the chassis. (See Dia. 4-2 or 4-3)

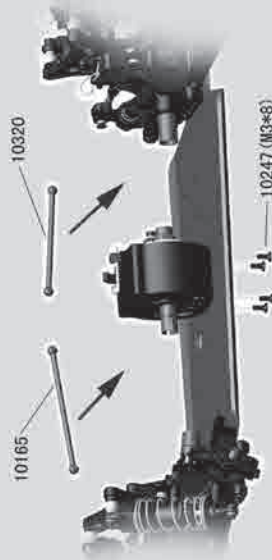

8. Tighten the engine assembly to the chassis. (See Dia. 4-1)

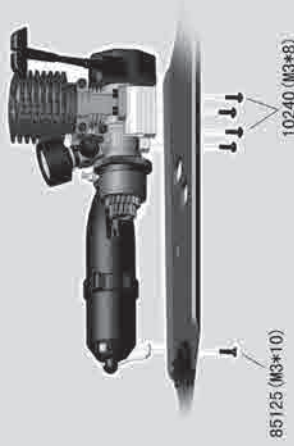

9. Finally assemble the receiver box assembly, throttle/steering servos assembly to the chassis. Setup the radio system and then assemble the cutted body to the body posts. (See Dia. 5-1, 5-2, 5-3)

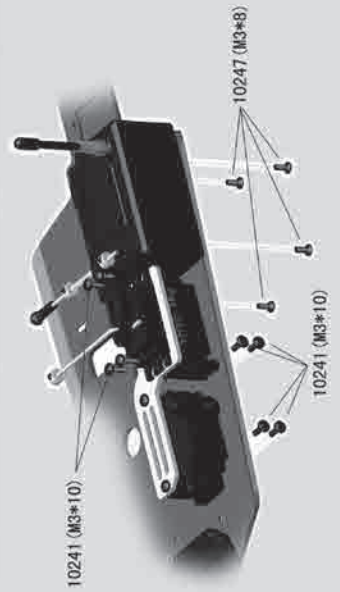

INSTRUCTION MANUAL

RH1027 XR4 EBD (Brushed)

RH1028 XR4 EBL (Brushless)

Specs :

- 1、 Length: 465mm
- 2、 Width: 256mm
- 3、 Height: 180mm
- 4、 Wheelbase: 275/280mm
- 5、 Gear Ratio: 8.3 : 1
- 6、 Tyre: Ø95*40

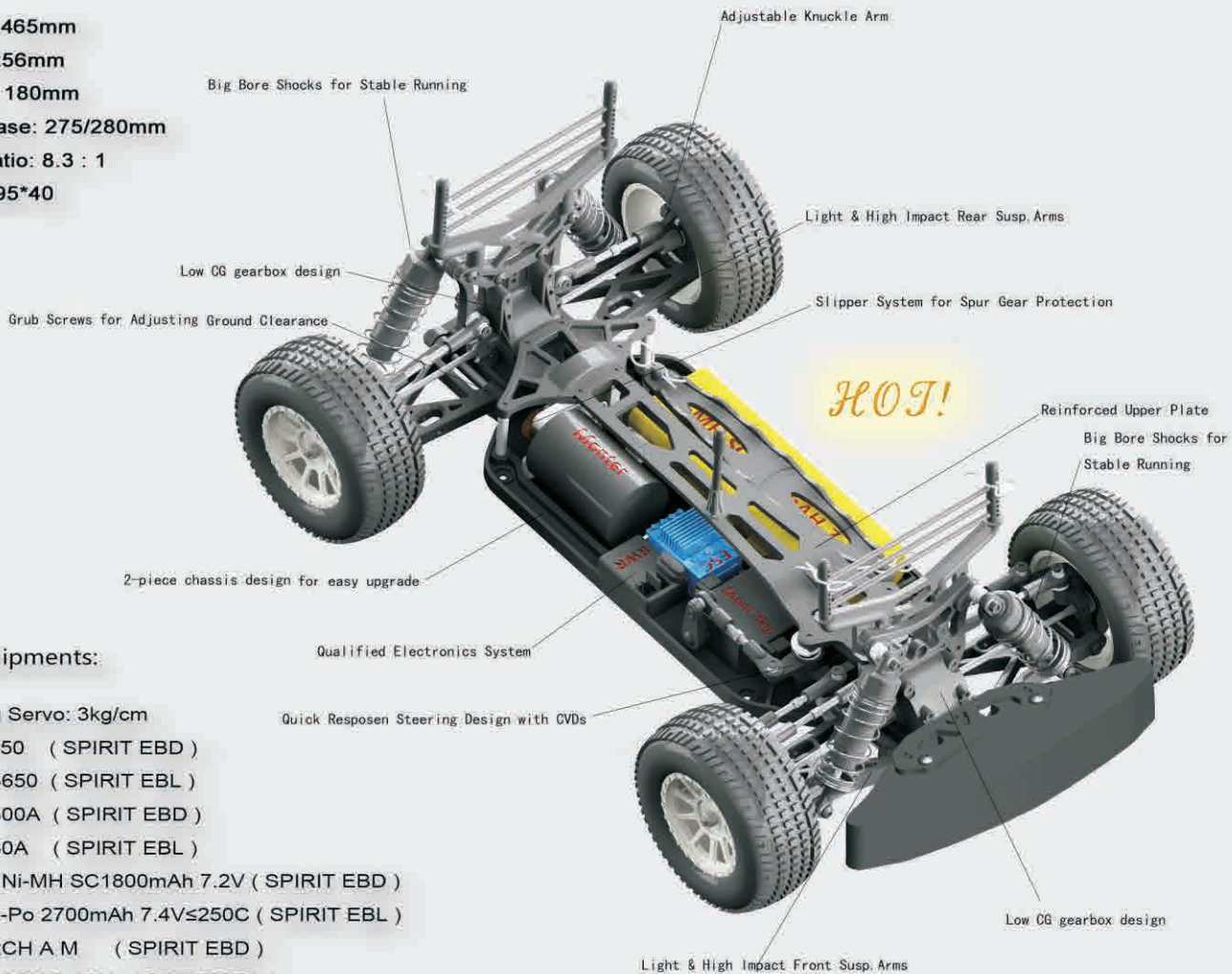

Standard Equipments:

- 1、 Steering Servo: 3kg/cm
- 2、 Motor: 550 (SPIRIT EBD)
3650 (SPIRIT EBL)
- 3、 ESC: 300A (SPIRIT EBD)
30A (SPIRIT EBL)
- 4、 Battery: Ni-MH SC1800mAh 7.2V (SPIRIT EBD)
Li-Po 2700mAh 7.4V≤250C (SPIRIT EBL)
- 5、 Radio: 2CH A M (SPIRIT EBD)
2CH 2.4GHz (SPIRIT EBL)

SPIRIT EBL Brushless System Set:

SPIRIT EBD Brushed System Set:



XR4 EBD and EBL is almost same but in electronics. XR4 EBD comes with brushed system and XR4 EBL with brushless system. For hobbyists, we have optional front and rear sway bar for upgrade, which adds higher racing performance.

Other assemblies please refer to Page 4 and XR4 N1 instructions.

Optional Front & Rear Sway Bar #10325.

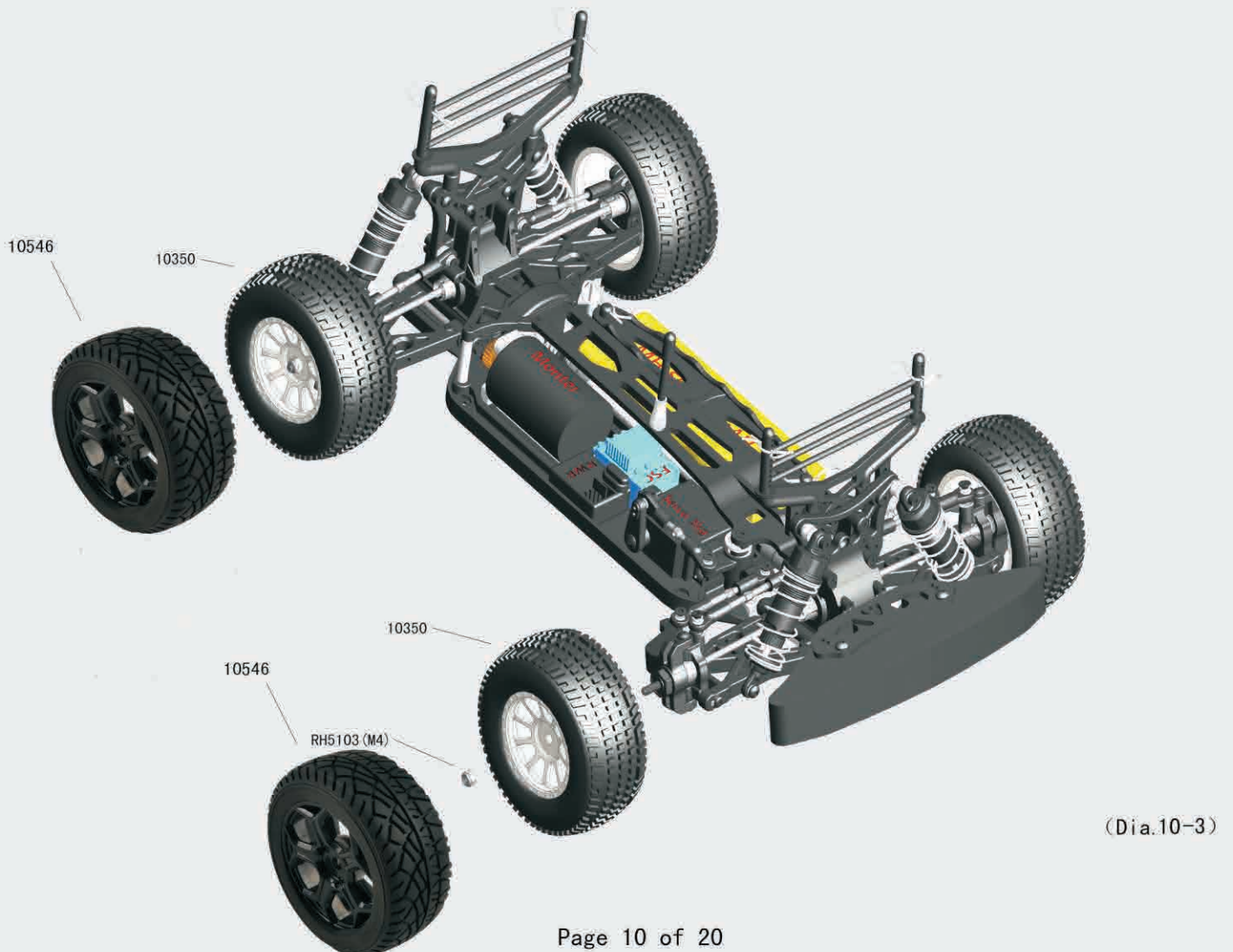
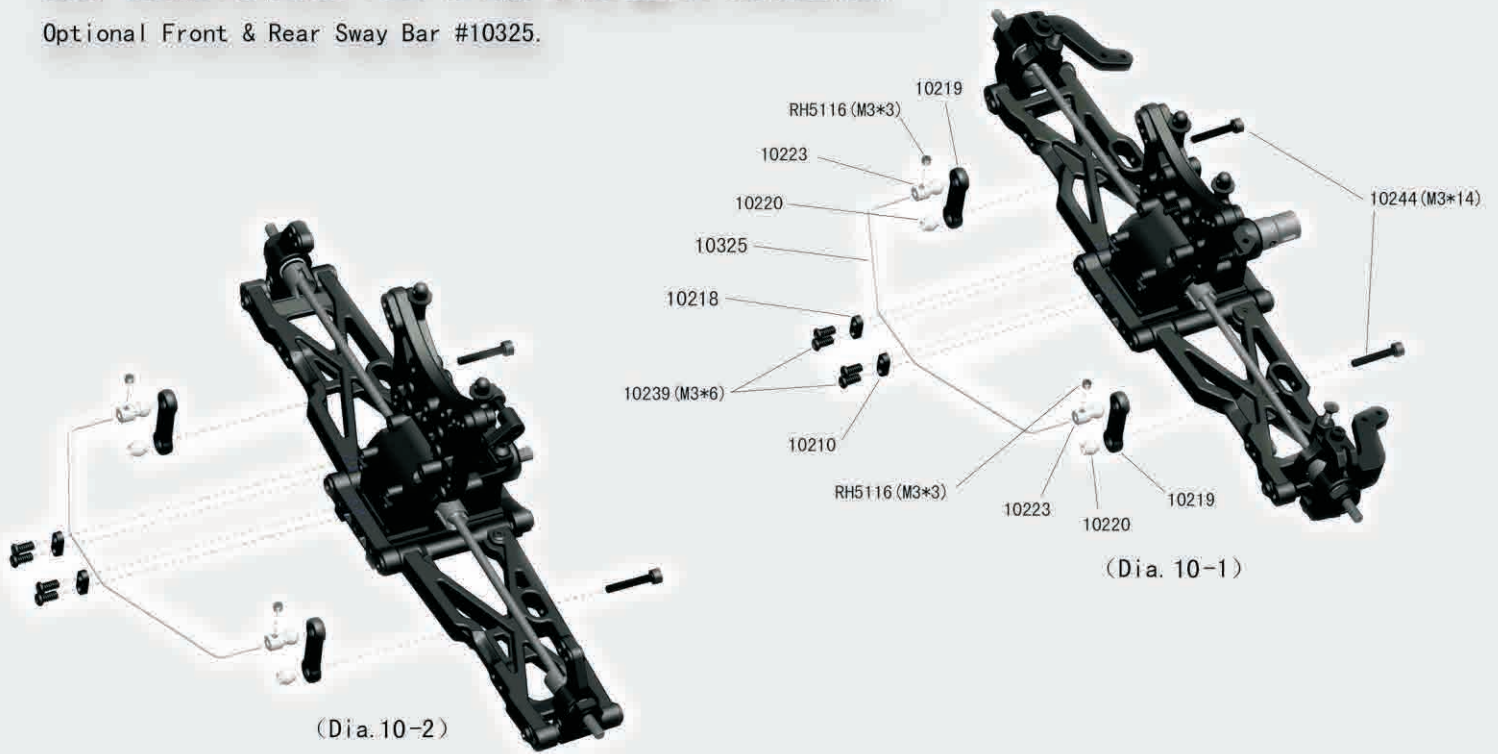

ASSEMBLY STEPS:

1. Assemble center chassis part (See Dia. 9-1)



2. Assemble Front Bumper Assembly to chassis rear part. (See Dia. 9-2)

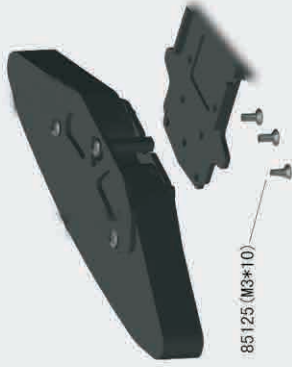

3. Assemble front assembly to chassis front. (See Dia. 3-1)

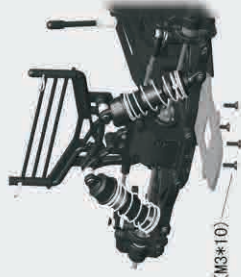

4. Assemble rear assembly to chassis rear part. (See Dia. 3-4)



5. Mount the wheels. (See Dia. 5-4, 5-5)



RH5103 (M4)

6. Mount the motor assembly and central drive shaft. (See Dia. 9-6)

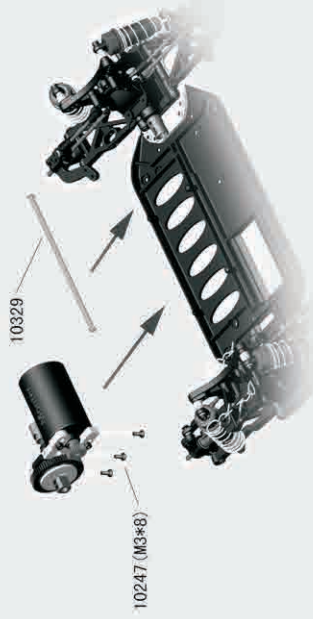

10247 (M3*8)

10329

7. Assemble steering servo and linkage. (See Dia. 9-4)



10240 (M3*8)

8. Assemble ESC, receiver, battery and connect them to setup. (See Dia. 9-4, 9-7)

Brushless System:

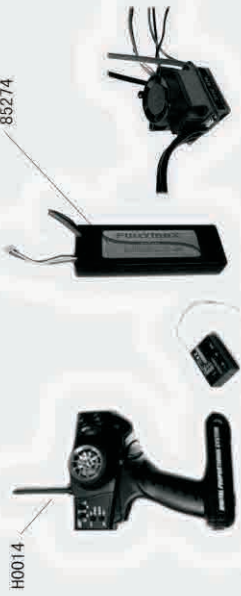

H0014

85274

H0013

Brushed system:















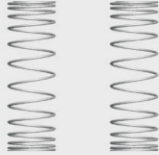







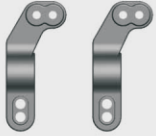

H0030



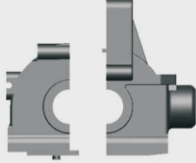





















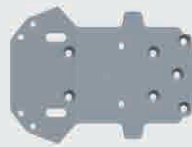

R0159

Common Part List

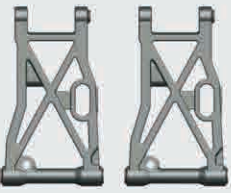
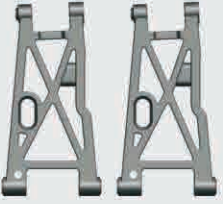
<p>10353 - Front Shock Tower 1pc</p>  <p>RH1027/RH1028/RH1029/RH1030</p>	<p>10354 -Rear Shock Tower 1pc</p>  <p>RH1027/RH1028/RH1029/RH1030</p>	<p>10001-Front Shocks 2pc (GP) 10021-Front Shocks 2pc (GP)</p>  <p>10007-Front Shocks 2pc (EP) 10023-Front Shocks 2pc (EP)</p>	<p>10002- Rear Shock Tower 2pc (GP) 10022- Rear Shock Tower 2pc (GP)</p>  <p>10008 - Rear Shock Tower 2pc (EP) 10024- Rear Shock Tower 2pc (EP)</p>
<p>10103-Front Shock Spring 2pc (GP) 10333-Front Shock Spring 2pc (EP)</p> 	<p>10104-Rear Shock Spring 2pc (GP) 10334-Rear Shock Spring 2pc (EP)</p> 	<p>10105-Front Shock Shaft & Piston Set 2sets</p>  <p>RH1027/RH1028/RH1029/RH1030</p>	<p>10106-Rear Shock Shaft & Piston Set 2sets</p>  <p>RH1027/RH1028/RH1029/RH1030</p>
<p>10107-Front Shock Body 2pc</p>  <p>RH1027/RH1028/RH1029/RH1030</p>	<p>10108-Rear Shock body 2pc</p>  <p>RH1027/RH1028/RH1029/RH1030</p>	<p>10539-Shock Upper Cap 2sets</p>  <p>RH1027/RH1028/RH1029/RH1030</p>	<p>10540-Shock Lower Caps 2sets</p>  <p>RH1027/RH1028/RH1029/RH1030</p>
<p>10538-Shock Lower holder & Adjust Ring 2sets</p>  <p>RH1027/RH1028/RH1029/RH1030</p>	<p>10114-Steering Knuckle Arm 1set</p>  <p>RH1027/RH1028/RH1029/RH1030</p>	<p>10115-Uprights 2pc</p>  <p>RH1027/RH1028/RH1029/RH1030</p>	<p>10117-Rear Hub Carrier 2pc</p>  <p>RH1027/RH1028/RH1029/RH1030</p>
<p>10118-Rear Drive Shaft 2pc</p>  <p>RH1027/RH1028/RH1029/RH1030</p>	<p>10120-Front Susp. Holders 2pc</p>  <p>RH1027/RH1028/RH1029/RH1030</p>	<p>10121-Rear Susp. Holders 2pc</p>  <p>RH1027/RH1028/RH1029/RH1030</p>	<p>10123-Gearbox Housing Set 2pcs</p>  <p>RH1027/RH1028/RH1029/RH1030</p>
<p>RH5526-Diff 16T Gear Washer 6pcs</p>  <p>RH1027/RH1028/RH1029/RH1030</p>	<p>10124-Diff. Drive Gear w/pin 2sets</p>  <p>13T</p> <p>RH1027/RH1028/RH1029/RH1030</p>	<p>10003-Diff Gearbox Set 1set</p>  <p>RH1027/RH1028/RH1029/RH1030</p>	<p>10125-Diff Case 2pcs</p>  <p>RH1027/RH1028/RH1029/RH1030</p>

Common Part List

<p>10126-Diff Drive Spur Gear 2pcs</p>  <p>38T</p> <p>RH1027/RH1028/RH1029/RH1030</p>	<p>10127-Diff Drive Gear 2pcs</p>  <p>13T</p> <p>RH1027/RH1028/RH1029/RH1030</p>	<p>10128-Diff Bevel Gear S. 4pcs</p>  <p>10T</p> <p>RH1027/RH1028/RH1029/RH1030</p>	<p>10129-Diff Bevel Gear B. 4pcs</p>  <p>13T</p> <p>RH1027/RH1028/RH1029/RH1030</p>
<p>10130-Diff Pin 2pcs</p>  <p>RH1027/RH1028/RH1029/RH1030</p>	<p>10131-Washer 6pcs</p>  <p>RH1027/RH1028/RH1029/RH1030</p>	<p>10132-Diff Drive Cup 4pcs</p>  <p>RH1027/RH1028/RH1029/RH1030</p>	<p>10133-Center Coupler 3pcs</p>  <p>RH1027/RH1028/RH1029/RH1030</p>
<p>10135-Servo Saver (GP) 1set</p>  <p>RH1029/RH1030</p>	<p>10136-Servo Saver Post 2pcs</p>  <p>RH1027/RH1028/RH1029/RH1030</p>	<p>10137-Steering Ackerman</p>  <p>RH1027/RH1028/RH1029/RH1030</p>	<p>10145-Wheel Hub 4pcs</p>  <p>RH1027/RH1028/RH1029/RH1030</p>
<p>10146-Antenna Pipe Set 2sets</p>  <p>RH1027/RH1028/RH1029/RH1030</p>	<p>10147-Servo Saver (EP) 1set</p>  <p>RH1027/RH1028</p>	<p>10350-SC truck wheel complete 2sets</p>  <p>RH1027/RH1028/RH1029/RH1030</p>	<p>10351-SC truck tyre & insert 2sets</p>  <p>RH1027/RH1028/RH1029/RH1030</p>
<p>10352-SC truck rim 2pcs</p>  <p>RH1027/RH1028/RH1029/RH1030</p>	<p>10309-Front CVD 2sets</p>  <p>RH1027/RH1028/RH1029/RH1030</p>	<p>10542 -Chassis Front Part 1pc</p>  <p>RH1027/RH1028/RH1029/RH1030</p>	<p>10409-Bumper Rail 1pc</p>  <p>RH1027/RH1028/RH1029/RH1030</p>
<p>10311-Front Lower Susp. Arm 2pc</p>  <p>RH1027/RH1028/RH1029/RH1030</p>	<p>10312-Rear Lower Susp. Arm 2pc</p>  <p>RH1027/RH1028/RH1029/RH1030</p>	<p>10316-Servo Linkage 1pc</p>  <p>10317-Front Upper Susp. Arm 2sets</p>  <p>RH1027/RH1028/RH1029/RH1030</p>	<p>10318-Rear Upper Susp. Arm 2sets</p>  <p>RH1027/RH1028/RH1029/RH1030</p>























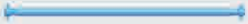

Part List

<p>10319-Steering Arm 2sets</p>  <p>RH1027/RH1028/RH1029/RH1030</p>	<p>10320-Central Dongbone R. 1pc</p>  <p>RH1029/RH1030</p>	<p>10321-Chassis Plate Rear Part 1pc</p>  <p>RH1029/RH1030</p>	<p>10151-Manifold Gasket 6pc</p>  <p>RH1029/RH1030</p>
<p>10152-Metal Bushing 15*10*4. 6pc</p> 	<p>10153-Metal Bushing 8*5*2.5 6pc</p> 	<p>10154-Servo & Upper Plate Mounts 1set</p>  <p>RH1029/RH1030</p>	<p>10156-Upper Plate 1pc</p>  <p>RH1029/RH1030</p>
<p>10157-Upper Steering Plate</p>  <p>RH1029/RH1030</p>	<p>10004-Fuel tank Set 1set</p>  <p>RH1029/RH1030</p>	<p>10158-Fuel Line 2pcs</p>  <p>RH1029/RH1030</p>	<p>10159-Front/Rear Chassis Brace</p>  <p>RH1029/RH1030</p>
<p>10160-Receiver Box 1set</p>  <p>RH1029/RH1030</p>	<p>85026-Switch Cover 2pcs</p>  <p>RH1029/RH1030</p>	<p>10161-Servo Horns</p>  <p>RH1029/RH1030</p>	<p>10162-Chassis Brace mount 1pc</p>  <p>RH1029/RH1030</p>
<p>10163-Stopper 6pcs</p>  <p>RH1029/RH1030</p>	<p>10164-Throttle Linkage 1set</p>  <p>RH1029/RH1030</p>	<p>10165-Central Dongbone F. 1pc</p>  <p>RH1029/RH1030</p>	<p>P0010-GO. 18 engine 1pc P0011-SH. 18 Engine 1pc</p>  <p>RH1029/RH1030</p>
<p>10167-Air filter 1Set</p>  <p>RH1029/RH1030</p>	<p>10168-Tuned Pipe 1Set</p>  <p>RH1029/RH1030</p>	<p>10169-Silicone Coupler 1Set</p>  <p>RH1029/RH1030</p>	<p>85195-Zip Tie 6pcs</p>  <p>RH1029/RH1030</p>













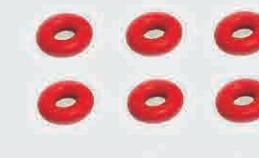
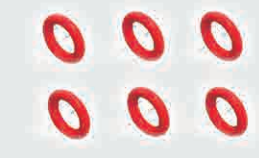

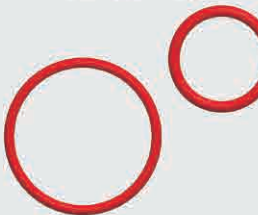



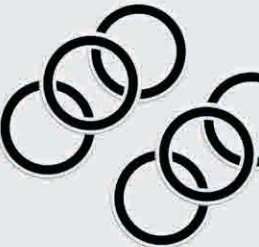
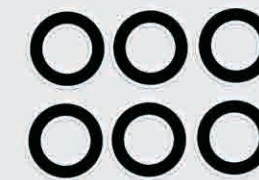

Part List

<p>10170-Manifold 1Set</p>  <p>RH1029/RH1030</p>	<p>85035-Flywheel 1pc</p>  <p>RH1029/RH1030</p>	<p>85087-Clutch Nut 2pcs</p>  <p>RH1029/RH1030</p>	<p>85045-Clutch Shoes & Springs</p>  <p>RH1029/RH1030</p>
<p>10173-Engine mount 2pcs</p>  <p>RH1029/RH1030</p>	<p>10331-Clutch Bell (16T) 1pc</p>  <p>RH1029</p>	<p>10322-Clutch Bell (21T) 1pc</p>  <p>RH1030</p>	<p>10005-Central Transmission Complete 1Set (Single Speed)</p>  <p>RH1029</p>
<p>10174-Central Transmission Bulkheads 2pcs</p>  <p>RH1029/RH1030</p>	<p>10175-Brake Post 1Set</p>  <p>RH1029/RH1030</p>	<p>10176-Brake Set 1set</p>  <p>RH1006/RH1007</p>	<p>10177-Brake Cup 2pcs</p>  <p>RH1029/RH1030</p>
<p>10178-Single Speed Shaft w/pin</p>  <p>RH1029</p>	<p>10179-50T Gear (Single Speed) 1pc</p>  <p>RH1029</p>	<p>10006-Central Transmission Complete 1Set (Two Speed)</p>  <p>RH1030</p>	<p>10180-Two Speed Clutch 1Set</p>  <p>RH1030</p>
<p>10181-Two Speed Shaft 1pc</p>  <p>RH1030</p>	<p>10182-50T Two Speed Gear 1pc</p>  <p>RH1030</p>	<p>10183-45T Two Speed Gear 1pc</p>  <p>RH1030</p>	<p>10185-Battery Cover (EP) 1pc</p>  <p>RH1027/RH1028</p>
<p>10188-Battery Post 2sets</p>  <p>RH1027/RH1028</p>	<p>10189-Post for Rear Spur Gear Cover 2pc</p>  <p>RH1027/RH1028</p>	<p>10190-Motor Mount (EP) 1pc</p>  <p>RH1027/RH1028</p>	<p>10191-Slipper Complete (EP) 1set</p>  <p>RH1027/RH1028</p>





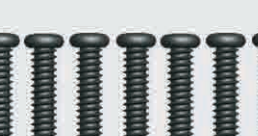















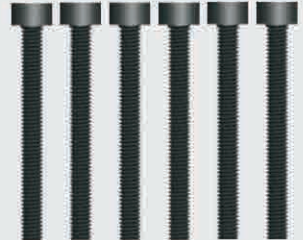

Part List

<p>10192-Slipper Pad (EP) 2pc</p>  <p>RH1027/RH1028</p>	<p>10193-Slipper Gasket (EP) 2pc</p>  <p>RH1027/RH1028</p>	<p>10194-65T Spur Gear (EP) 1pc</p>  <p>RH1027/RH1028</p>	<p>10195P-Slipper Shaft (EP) 1pc</p>  <p>RH1027/RH1028</p>
<p>10196-Slipper Spring Bracket (EP) 1pc</p>  <p>RH1027/RH1028</p>	<p>10197-Slipper Spring (EP) 1pc</p>  <p>RH1027/RH1028</p>	<p>10198-Slipper Coupler (EP) 1pc</p>  <p>RH1027/RH1028</p>	<p>10199-Slipper Drive Cup 1pc</p>  <p>RH1027/RH1028</p>
<p>10200-BEARING BRACKET (EP) 1pc</p> 	<p>10323-Pinion Gear 23T (EP) 1pc</p>  <p>RH1027/RH1028</p>	<p>10324-Sway Bar 2Sets</p>  <p>RH1027/RH1028/RH1029/RH1030</p>	<p>10325-EP Chassis plate 1pc</p>  <p>RH1027/RH1028</p>
<p>10326-Rear Spur Gear Cover (EP) 1pc</p>  <p>RH1027/RH1028</p>	<p>10327-Upper plate (EP) 1pc</p>  <p>RH1027/RH1028</p>	<p>10328-Center Drive Shaft (EP) 1pc</p>  <p>RH1027/RH1028</p>	<p>85034-Body Clip (Medium Size) 6pcs</p> 
<p>85029-Body Clip (Small Size) 6pcs</p> 	<p>10214-Shock Ball End 6pcs</p> 	<p>10215-Servo Link Ball End 6pcs</p> 	<p>10216-Steering Linkage Ball End 6pcs</p> 
<p>10217-Rear Upper Linkage Ball End 6pcs</p> 	<p>10218-Sway Bar Fix Plate 6pcs</p> 	<p>10219-Sway Bar Holders 6pcs</p> 	<p>10220-Ball A 6pcs</p> 

Part List

<p>10221-Ball B 6pcs</p> 	<p>10222-Ball C 6pcs</p> 	<p>10223-Ball D 6pcs</p> 	<p>10224-Shock O-ring(Lower) 6pcs</p> 
<p>10225-Diff O-ring Seal 6pcs</p> 	<p>10226-Shock seal cover 4pcs</p> 	<p>10227-Tuned Pipe Seal & Fuel Tank Seal 1set</p> 	<p>10228-Pin, ϕ2*10 6pcs</p> 
<p>10229-Pin ϕ2*11 6pcs</p> 	<p>10329-Hinge Pins(long & short) 1sets</p> 	<p>10231-One Way Bearing 3pcs</p> 	<p>10232-Ball Bearing 15*10*4 6pcs</p> 
<p>10233-Ball Bearing 10*5*4 6pcs</p> 	<p>10234-Metal Bushing 10*5*4 6pcs</p> 	<p>10235-Ball Bearing 8*5*2.5 6pcs</p> 	<p>10236-E clip-8mm 4pc</p> 
<p>RH5190-E clip-4mm 6pc</p> 	<p>10237-E clip-2.5mm 6pc</p> 	<p>RH5102-Nylon Lock Nut M3 6pc</p> 	<p>RH5103-Nylon Lock Nut-M4 6pc</p> 
<p>85148-Round Head Self Tapping Hex Screw 2*6 4pcs</p> 	<p>10238-Round Head Self Tapping Hex Screw 2*10 6pc</p> 	<p>85179-Round Head Self Tapping Hex Screw 3*15 8pc</p> 	<p>10239-Round Head Self Tapping Hex Screw M3*6 6pc</p> 

Part List

<p>10240-Button Head Hex Screw M3*8 6pc</p> 	<p>10241-Button Head Hex Screw M3*10 6pc</p> 	<p>85184-Button Head Hex Screw M3*12 6pc</p> 	<p>10242-Button Head Hex Screw M3*14 6pc</p> 
<p>85144-Ring Self Tapping Screw 3*44pc</p> 	<p>RH5116-Set Screw M3*3 6pc</p> 	<p>RH5117-Set Screw M4*4 6pc</p> 	<p>85133-Button Head Hex Screw M4*10 6pc</p> 
<p>RH5562-Cap Head Hex Screw M3*8 6pc</p> 	<p>10243-Cap Head Hex Screw M3*10 6pc</p> 	<p>85182-Cap Head Hex Screw M3*10 6pc</p> 	<p>10244-Cap Head Hex Screw M3*14 6pc</p> 
<p>10245-Cap Head Hex Screw M3*18 6pc</p> 	<p>85118-Cap Head Hex Screw M3*15 6pc</p> 	<p>85185-Cap Head Hex Screw M3*25 6pc</p> 	<p>10246-Cap Head Hex Screw M3*28 6pc</p> 
<p>10247-Flat Head Hex M3*8 6pc</p> 	<p>85125-Flat Head Hex Screw M3*10 8p</p> 	<p>10248-Flat Head Hex Screw M3*12 6p</p> 	<p>10249-Flat Head Hex Screw M3*14 6p</p> 
<p>85127-Flat Head Hex Screw M3*18 3p</p> 	<p>10250-Flat Head Hex Screw M3*20 6p</p> 	<p>10251-Flat Head Hex Screw M3*36 6p</p> 	<p>10541-Button Head Hex Screw M4*6 6pc</p> 

Part List

<p>10253 - 1/10 Charger CE 1pc 10254 - 1/10 Charger UL 1pc 10255 - 1/10 Charger BS 1pc</p> 	<p>85274-Li-Po 2700mAh 7.4V 1pc</p> 	<p>H0028 - 3650 Brushless Motor 1pc</p> 	<p>H0072 ks 45A ESC 1pc</p> 
<p>H0011 - 3kg/cm Servo 1pc</p> 	<p>H0029 - 550 Brushed Motor 1pc</p> 	<p>H0030 - Ni-MH 7.2V 1800mAh 1pc H0031 - Ni-MH 7.2V 3000mAh 1pc</p> 	<p>H0050-400A ESC 1pc</p> 
<p>H0012 - Battery Case 1pc RH5189 - Receiver Switch 1pc</p> 	<p>H0014 - 2.4GHz Transmitter 1pc</p> 	<p>H0068 2.4G FS-GT2 TX&RX</p> 	<p>R0159-Printed Body 1pc</p>  <p>RH1027/RH1028/RH1029/RH1030</p>
<p>R0162- Clear Body 1pc</p>  <p>RH1027/RH1028/RH1029/RH1030</p>	<p>10408-Sponge cover 1pcs</p>  <p>RH1027/RH1028/RH1029/RH1030</p>	<p>10543-Bumper sponge 1pc</p>  <p>RH1027/RH1028/RH1029/RH1030</p>	<p>10536-Front/Rear Body post 1set</p>  <p>RH1027/RH1028/RH1029/RH1030</p>
<p>10544-Rally tyre with foam 2pcs</p>  <p>RH1027/RH1028/RH1029/RH1030</p>	<p>10545-Rally rim 2pcs</p>  <p>RH1027/RH1028/RH1029/RH1030</p>	<p>10546-Rally tyre complete 2pcs</p>  <p>RH1027/RH1028/RH1029/RH1030</p>	<p>R0161-Printed Body 1pc</p>  <p>RH1027/RH1028/RH1029/RH1030</p>
			

Upgrade Parts List

<p>10961 - Front Shock Plate (Carbon) 1Set</p>  <p>RH1006/RH1007/RH1016/RH1017</p>	<p>10962 - Rear Shock Plate (Carbon) 1Set</p>  <p>RH1006/RH1007/RH1016/RH1017</p>	<p>10905 - Battery Cover (Carbon) 1set</p>  <p>RH1016/RH1017</p>	<p>10928 - Rear Lower Susp. Arm (AL) 2pc</p>  <p>RH1006/RH1007/RH1016/RH1017</p>
<p>10907 - Front Shocks (AL) 2pc</p>  <p>RH1006/RH1007/RH1016/RH1017</p>	<p>10908 - Rear Shocks (AL) 2pc</p>  <p>RH1006/RH1007/RH1016/RH1017</p>	<p>10911 - Steering Ackerman (AL) 1pc</p>  <p>RH1006/RH1007/RH1016/RH1017</p>	<p>10912 - Front Susp. Holders (AL) 1Set</p>  <p>RH1006/RH1007/RH1016/RH1017</p>
<p>10913 - Front & Rear Brace (AL) 1Set</p>  <p>RH1006/RH1007</p>	<p>10914 - Rear Susp. Holders (AL) 1Set</p>  <p>RH1006/RH1007/RH1016/RH1017</p>	<p>10915 - Rear Hub Carrier (AL) 2pc</p>  <p>RH1006/RH1007/RH1016/RH1017</p>	<p>10916 - Front Top Plate (Carbon) 1pc</p>  <p>RH1006/RH1007</p>
<p>10917 - Steering Knuckle Arm (AL) 2Set</p>  <p>RH1006/RH1007/RH1016/RH1017</p>	<p>10918 - Wheel Hub (AL) 4pc</p>  <p>RH1006/RH1007/RH1016/RH1017</p>	<p>10919 - Upper Plate (AL) 1pc</p>  <p>RH1006/RH1007</p>	<p>10920 - Tuned Pipe (AL) 1Set</p>  <p>RH1006/RH1007</p>
<p>10921 - Chassis Brace mount (AL) 1pc</p>  <p>RH1006/RH1007</p>	<p>10922 - Wheelie Set 1Set</p>  <p>RH1006/RH1007/RH1016/RH1017</p>	<p>10923 - Alum Steering Arm 2pc</p>  <p>RH1006/RH1007/RH1016/RH1017</p>	<p>10924 - Alum Knuckle Arm 2pc</p>  <p>RH1006/RH1007/RH1016/RH1017</p>
<p>85265 - Heatsink 1pc</p>  <p>RH1016/RH1017</p>			
<p>10925 - Chassis Plate (AL+Carbon) 1Set</p>  <p>RH1016/RH1017</p>	<p>10926 - Upper Plate (Carbon) 1pc</p>  <p>RH1016/RH1017</p>	<p>10927 - Front Lower Susp. Arm (AL) 2pc</p>  <p>RH1006/RH1007/RH1016/RH1017</p>	